

Clevertest Plus

Refer to the supplementary operation guide supplied with the Product.
After Power ON, the Status LED on a Clevertest Plus enabled fitting will display a rapid Green or Red flashing for a period up to 2 minutes.

Zoneworks HIVE Monitored Options

Fittings with part numbers -HV are fitted with Zoneworks communications modules (nodes). These fittings are monitored using RF transceiver modules operating in the ISM band. Zoneworks software on the server is used to monitor, coordinate testing and collate test data from each fitting. Zoneworks Fittings can be commissioned by a single push of the test switch or by scanning the supplied barcode. The LED Test Switch indicator provides a multifunction indication of the status of the fitting during testing and normal operation:

Option	State	LED Operation
HV, HVG	Commissioned	LED on Solid (Green)
HV, HVG	Un-commissioned With network connectivity	Batt plugged-in: yellow 1s, green 1s
		Batt unplugged: red 1s, off 1s
HV, HVG	Un-commissioned Without network connectivity	Batt plugged-in: yellow 250mS, green 250mS, yellow 250mS, green 250mS, green 1s
		Batt unplugged: red 250mS, off 250mS, red 250mS, off 250mS, off 1s
HV, HVG	Emergency Light Test In Progress	LED flashes at yellow 1s , Off 1s

For further information of installation of a Zoneworks system, please refer to the Zoneworks Users Guide and Commissioning Guide (incl. DATA version).

DALI EM Option

Fittings with part numbers having -DALI are fitted with DALI modules (nodes) that facilitate connection and integration to 3rd Party Lighting Control Systems. Before installing the -DALI luminaire, please confirm that the Lighting Control System has the capability to monitor DALI Emergency Luminaires. The -DALI fitting will be addressed and configured into the control system by the Lighting Control System Commissioning Technicians and not Clevertronics.

State	LED Operation
Commissioned/ Un-commissioned	LED on Solid (Green)
Emergency Light Test in progress	LED flashes at 1s On (Yellow) & 1s Off
"IDENTIFY COMMAND"	Lamp and Status LED Flash for 30 seconds

A 2-way "figure 8" cable and terminal block facilitates the connection to the DALI network. DALI connections are marked as Da Da.

Below are a list of common problems and their possible causes:

Fault: The Green LED indicator is not illuminated.

Check: A.C. is connected and is turned on.
Battery is connected.
Test Switch for damage.

Fault: Lamp does not illuminate in emergency mode.

Check: A.C. is connected.
Lamp is correctly inserted.
Battery is connected

Fault: Lamp illuminates in emergency mode, but only stays on for a short period.

Check: Battery has been allowed to charge for at least 24 hours.
Battery for damage.



LP™ 1500mm EPIC LED Batten Installation & Maintenance Instruction Leaflet

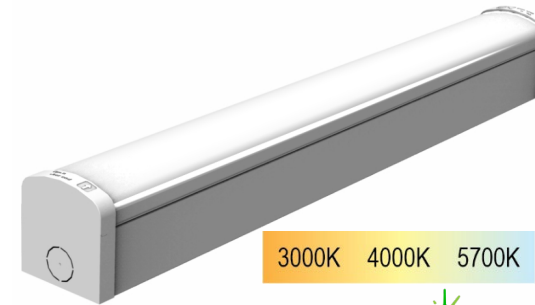

Designed in Australia to comply with the requirements of AS2293.3: 2018 and AS/NZS CISPR15: 2017

NOTE: Standard product codes with this symbol are enabled with Clevertest Plus capability. Please refer to the operation guide supplied with the product for details.

Victoria (Head Office & Manufacturing)

Website: www.clevertronics.com.au
Email: info@clevertronics.com.au
Phone: +61 3 9559 2700
Fax: +61 3 9559 2799

New South Wales

Phone: +61 2 8805 6400
Fax: +61 2 8805 6444

Queensland

Phone: +61 7 3442 9700
Fax: +61 7 3442 9777

South Australia/Northern Territory

Phone: +61 8 8301 8800
Fax: +61 8 8351 8286

Western Australia

Phone: +61 8 9207 0000
Fax: +61 8 9207 0088

New Zealand

Phone: +64 800 548 448

Models: EPIC-1500-yy-LP-xx

Testing:

Manual Test (CTP) xx = BLANK
Zoneworks HIVE xx = HV/HVG
DALI xx = DALI
DALI-2 xx = D2

Options:

Microwave Sensor yy = SEN (ON/OFF)
Dali 240V Driver yy = DD

Spare Parts:

1550230 Replacement Battery
1330069 Replacement 240V Driver
8050571 Replacement Emergency LED Board
AUM02370050002 Replacement Emergency Driver

Important:

It is illegal for anyone, except for a licensed electrician to install or maintain this product. Before installation, ensure that the electricity supply has been switched off and isolated. Installation must be carried out in accordance with the relevant Australian and International Standards.

Warranty:

For Product Warranty information and Terms and Conditions of Sales please refer to our website <http://clevertronics.com.au/terms-conditions-sale-australia-nz/>

Rated Emergency Lumen Output in accordance with AS2293.1, (refer to spacing tables for installation positions):

Refer to the Technical Label for classification information.

Installation:

This product can be mounted to any solid surface. Please follow the below installation steps:

- Refer Images below for the mounting hole and cable access.
- Remove the diffuser by leveraging a flat head screwdriver into the provided slot **(A)**. This is to be done on the end marked "Open this end". Once the endcap is unclipped hinge it away from the diffuser until a click is heard. Undo the diffuser securing screw **(B)**, lift diffuser away from body **(C)**.
- Disconnect the LED strip connector and EM LED connector. If connected unhook the lanyard
- Position the batten in the desired location.
- Mark out the fixing points on the mounting surface.
- Install appropriate fixing hardware.
- Route power supply cables through the access hole as the rear of the fitting or the ends if using surface conduit (punch out the knock-outs in the plastic end caps)
- Fasten the batten to the surface.
- Terminate the supply cable to the terminals marked L_{EM}, N, L_{SW} and E (240V AC/50Hz)
- Set Colour Switch to the desired colour (3000K, 4000K, 5700K)
- Attach the diffuser to lanyard, Re-connect the LED strip connector and EM LED connector.
- Re-install the diffuser, Tighten diffuser screw **(B)** and close endcap clip **(A)**.

NOTE: This luminaire (with reinforced insulation between control/LED terminal and AC Supply) contains non-user replaceable light source and battery – to be replaced (if required) by the manufacturer or his service agent or a similar qualified person.

Wiring:

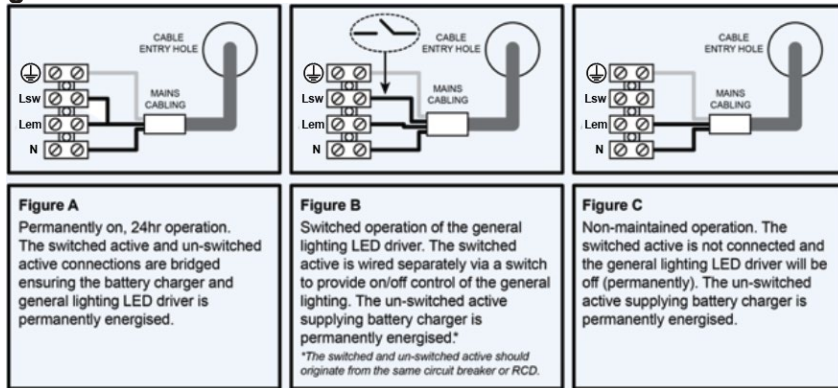

Sensor Version:

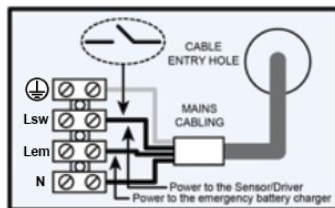

Colour Setting:

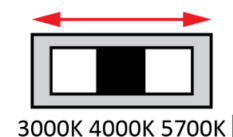

Dimensions:

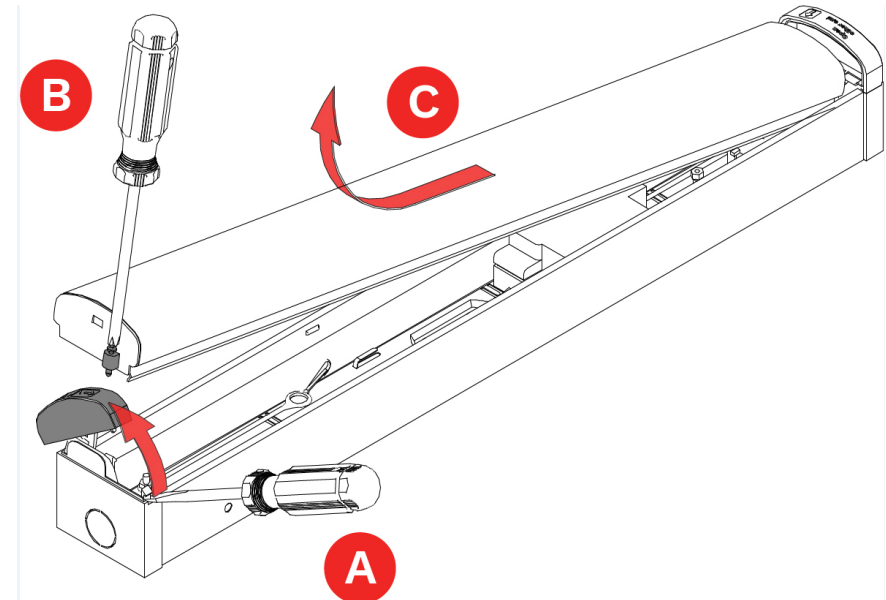
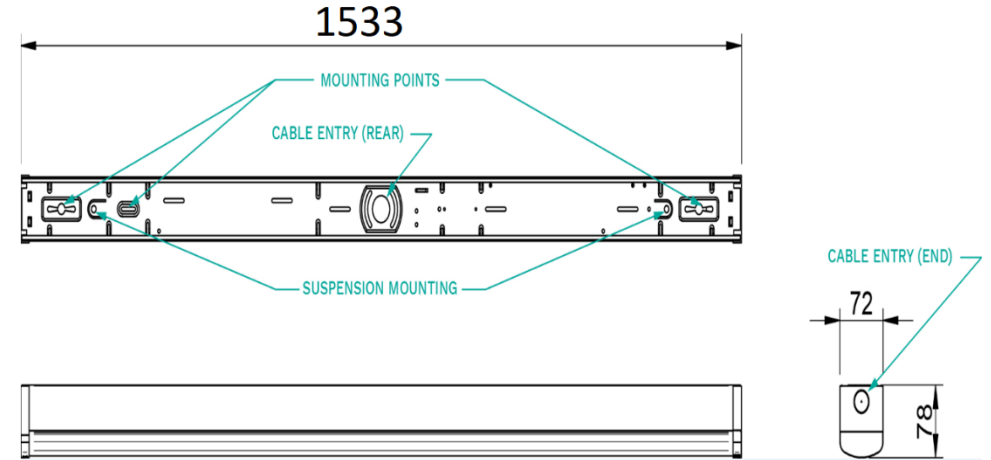

Testing:

Once connected to the 240V mains supply, the unit must be allowed to charge the battery for at least 24 hours. Conduct the following tests:

- For the first test, the emergency lamp must remain illuminated for at least 2 hours after disconnection from the mains supply.
- Subsequent tests require the unit to illuminate for at least 90 minutes. The results of all tests are required to be recorded in a service logbook, which is to be kept on-site at all times. If the unit fails to remain illuminated for the requisite time, remedial action must be taken to repair the situation and once completed, the unit must pass a subsequent test. For more specific information, please refer to the current edition of the AS 2293.3 Standard.